

QP-500 TYPE Take-up Machine

High Speed

Stable Operation

Neat Traverse Wire



PRODUCT PARAMETERS

Model Number	QP500
Fit Diameter	ø0.1-30mm round wire, flat wire, tube
Fit Coil	Outer diameter less than 500mm, inner hole 30-60mm, width less than 350mm
Take-up Speed	280 RPM (customizable speed)
Wiring Mode	rolling ring drive (L=500MM)
Load-Bearing	50KG
Motor Power	0.75KW+ speed reducer
Voltage	Single-phase power 220V 50HZ
Package Size	1.05*0.8*0.95m
weight	126KG

Optional	
Meter Count	Set the number of meters, and the machine will automatically alarm and stop when the number of meters is reached
Magnetic Particle	Equipped with assembly line to keep line speed synchronized and prevent strain
Torque Motor Controller	Automatically adjust the winding speed according to the torque

Product Size:

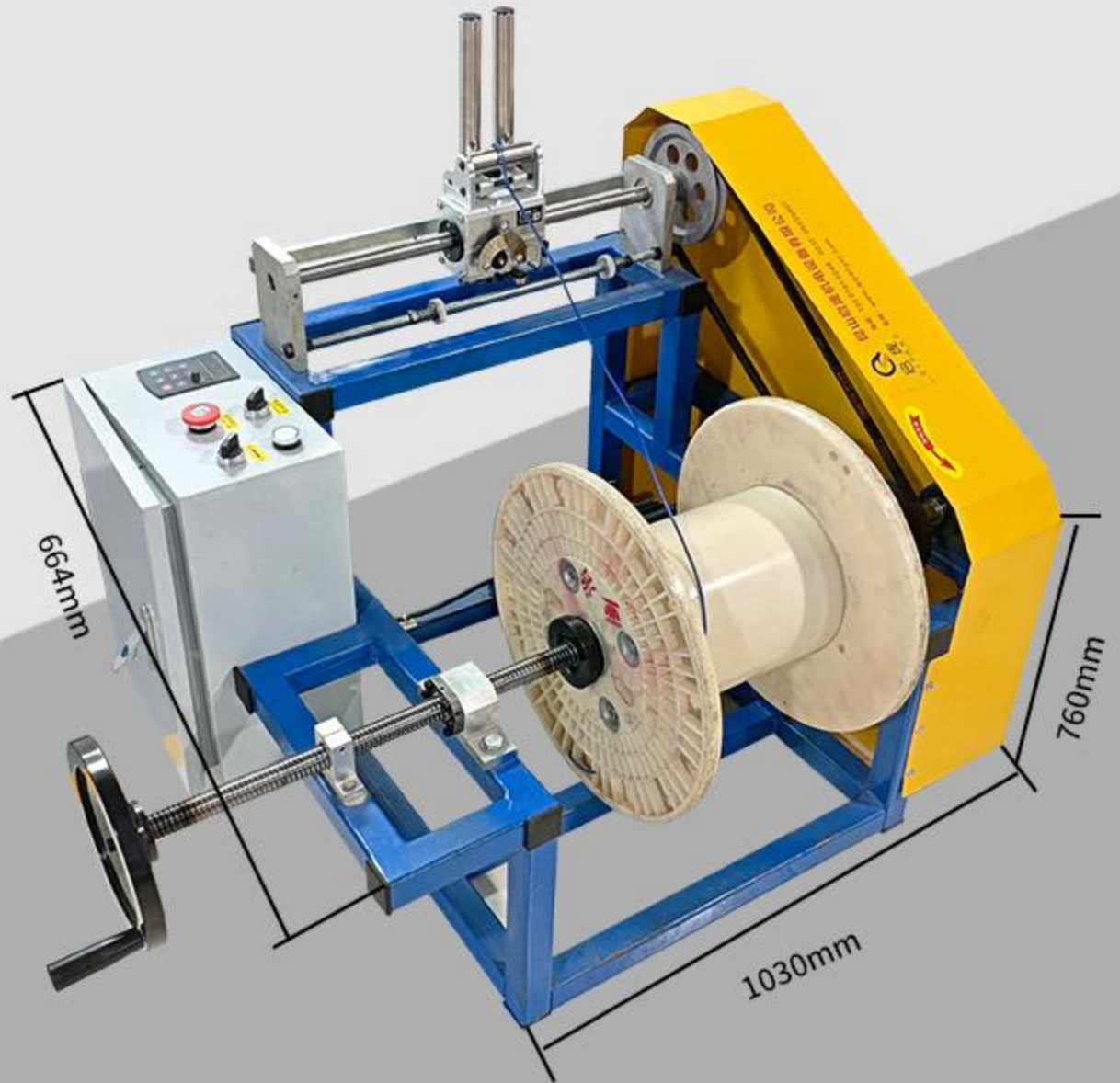

OPTIONAL

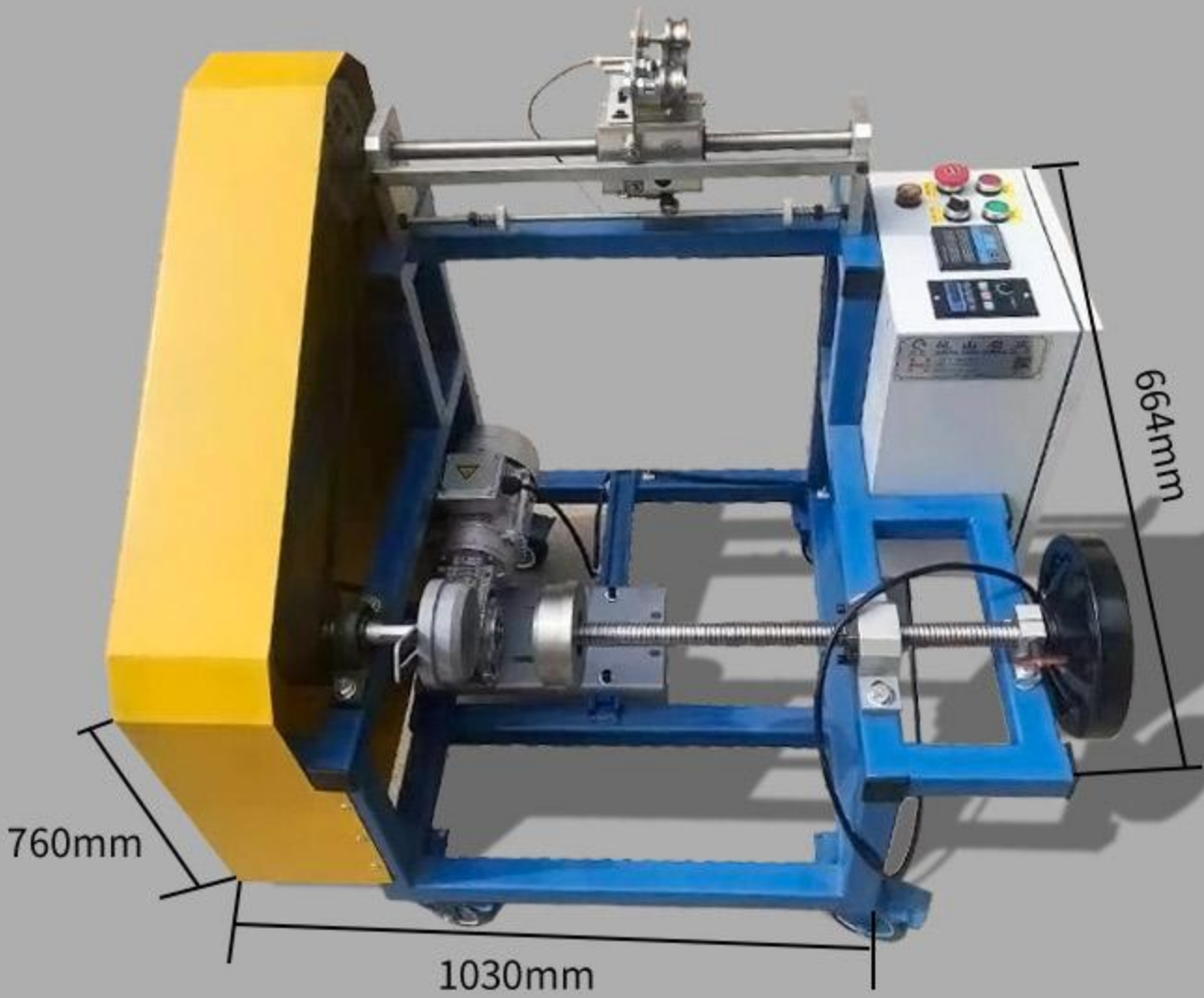

Optional 1



Meter Count

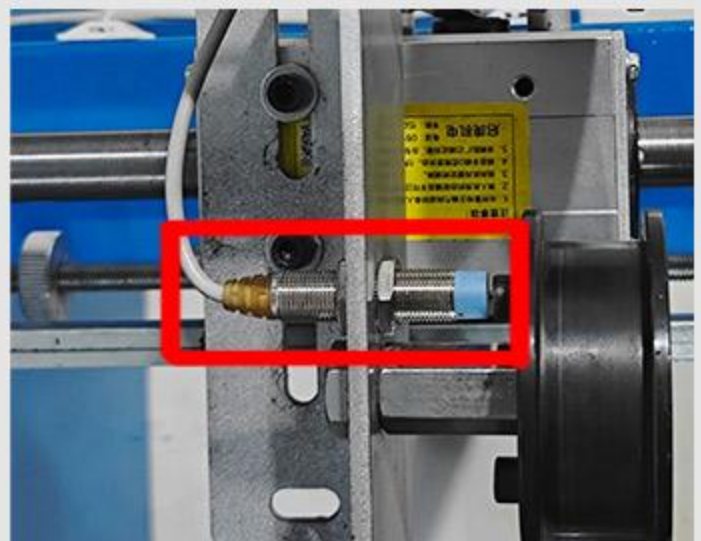

Induction Probe

Set the number of meters, and the machine will automatically alarm and stop when the number of meters is reached

Optional 2



Torque Motor Controller

Automatically adjust the winding speed according to the torque

Optional 3



Magnetic Particle

Equipped with assembly line to keep line speed synchronized and prevent strain

APPLICABLE TO VARIOUS LINES



Cable

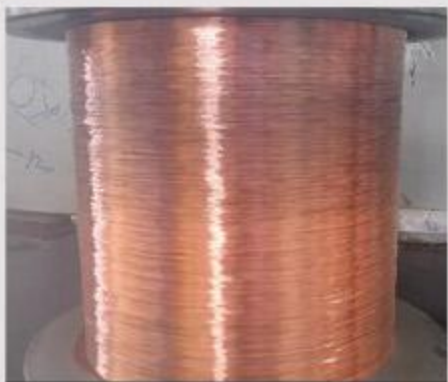

Copper Wire

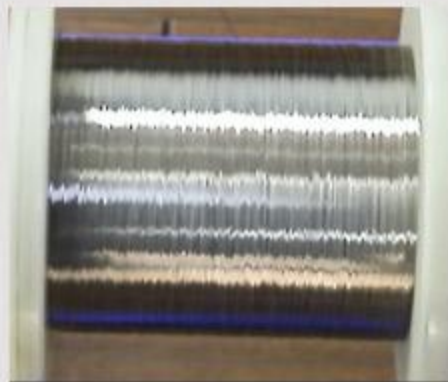

Aluminium Wire



Flat Wire



Adhesive Strip

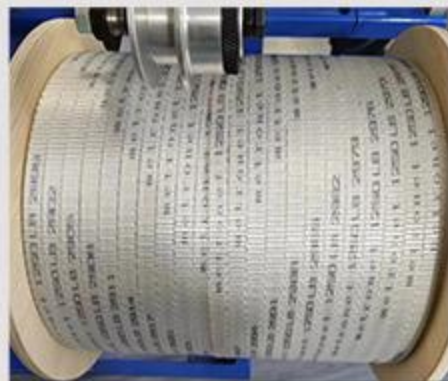

Flat Braided Wire

PRODUCT DETAILS

1



Panel: inverter, adjustable speed range, appropriate speed, emergency stop switch,

2

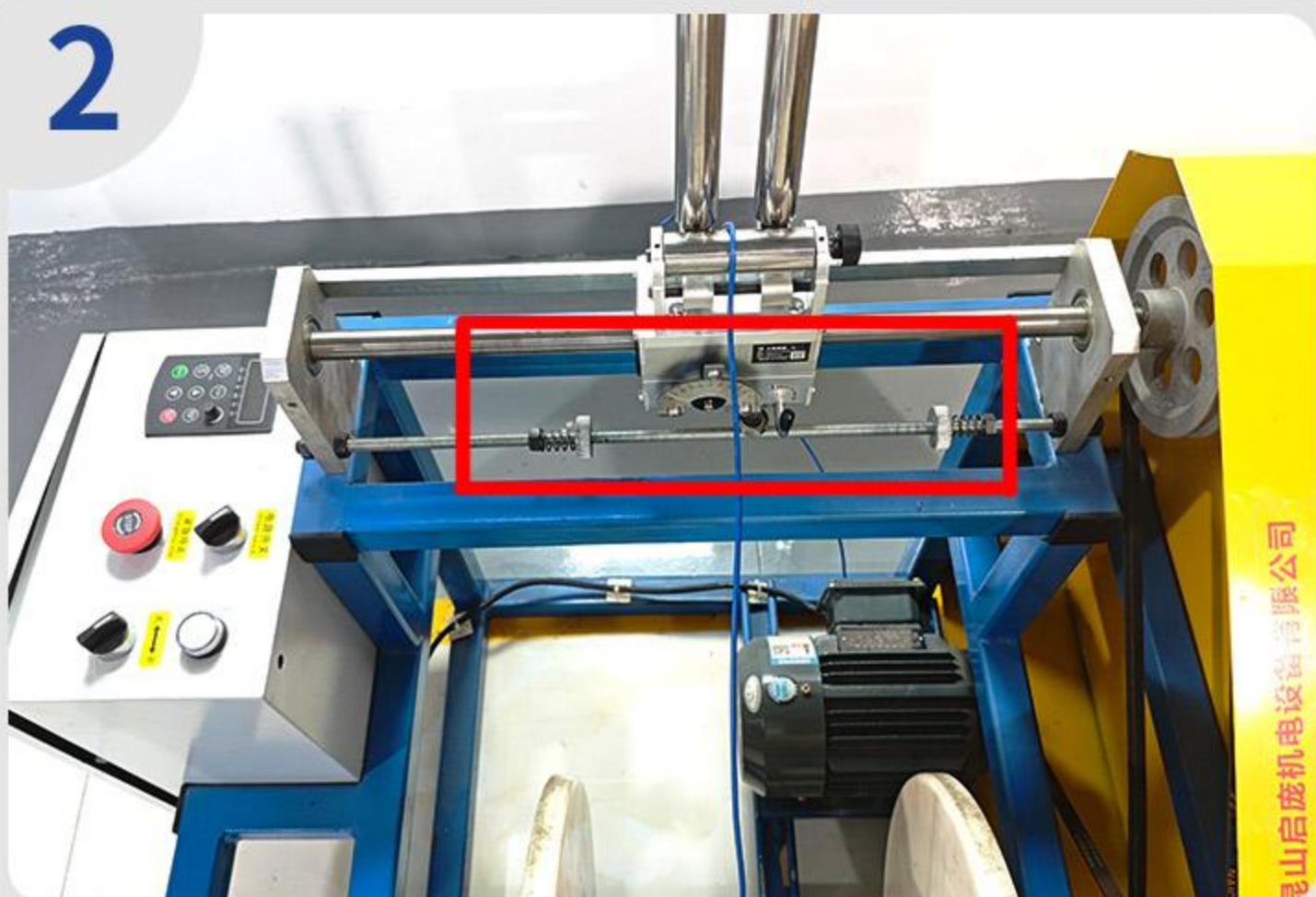

Rolling ring drive, the left and right widths can be adjusted to suit different reels

3



safety shield, Safety protection,Barrier dust

4

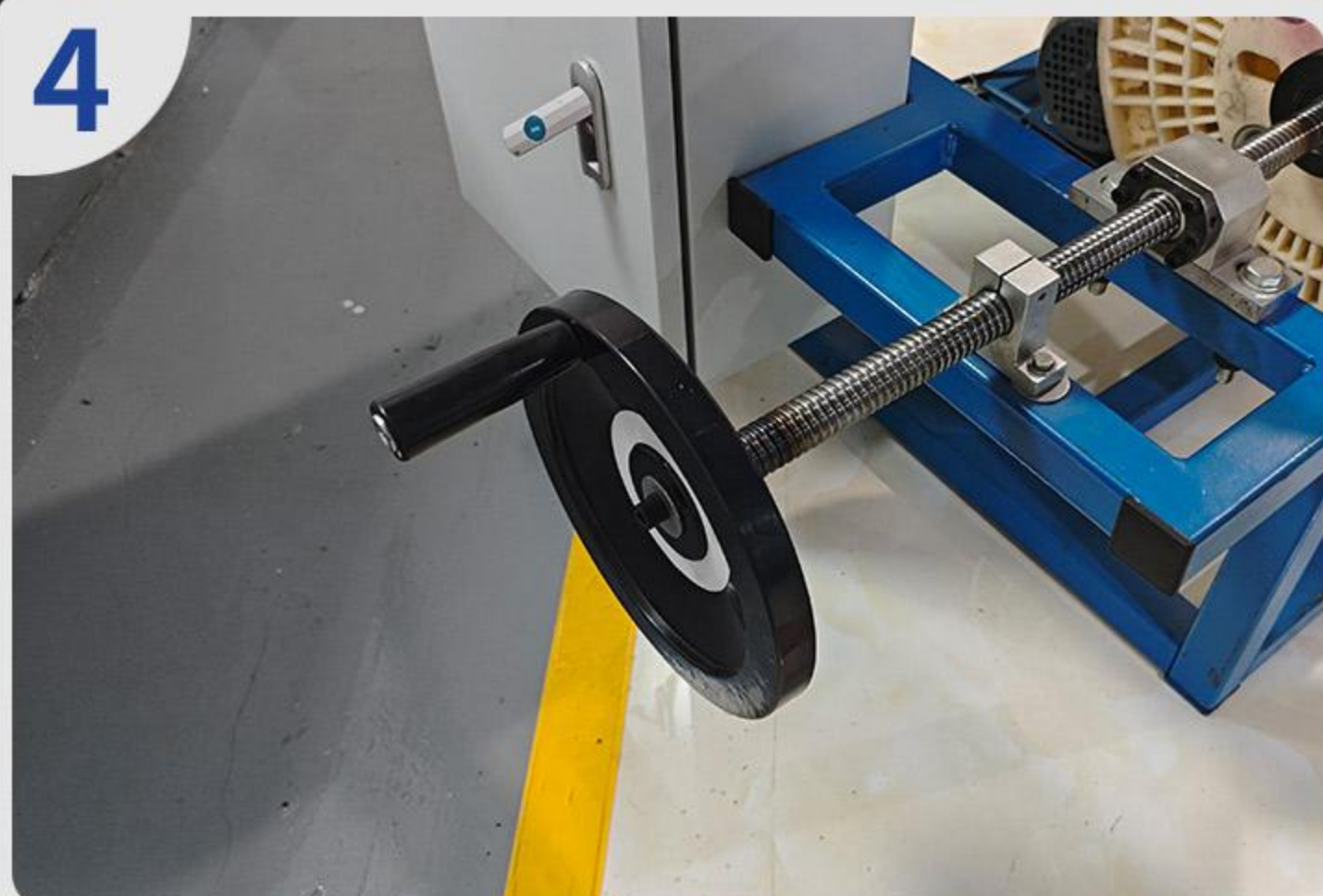

Hand screw for easy load and unload of reels

5



Easylock anti-skid device

5

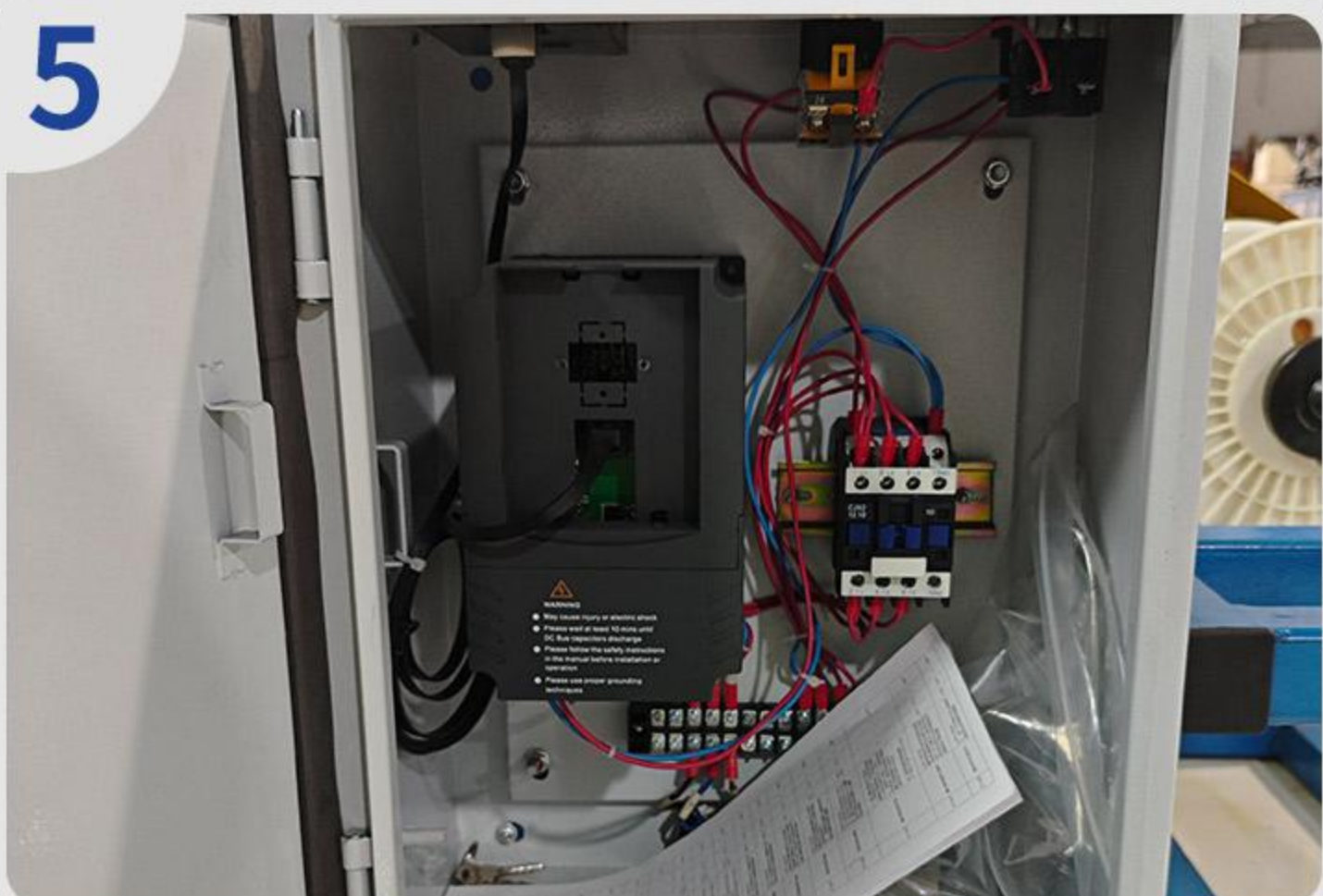

Electrical Enclosure

MASS PRODUCTION

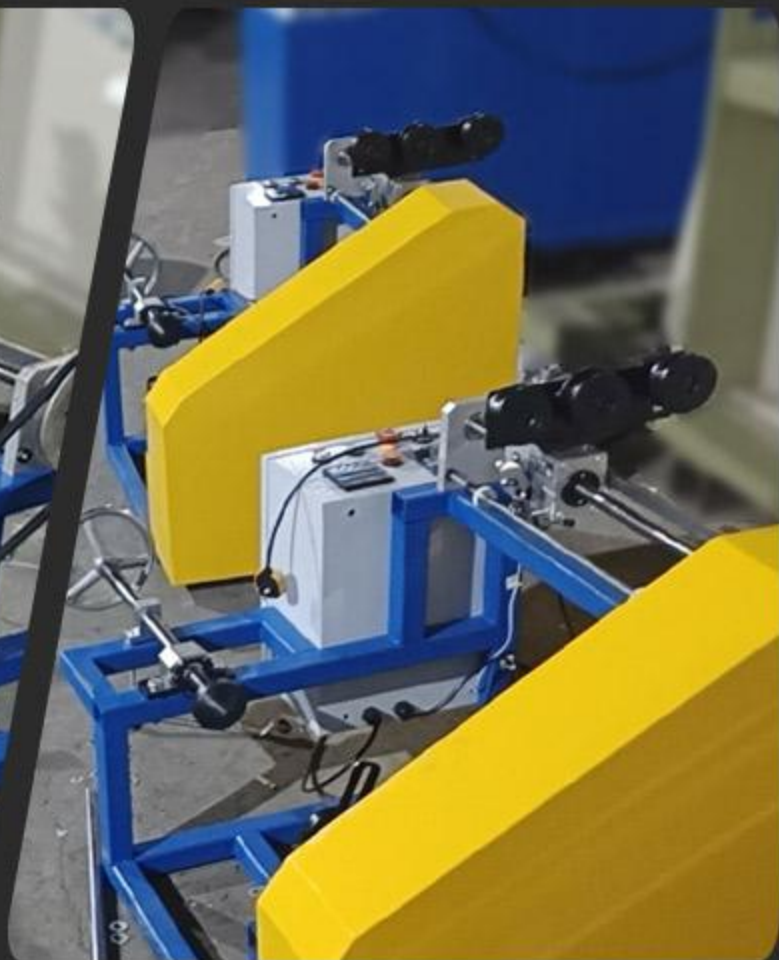

FACTORY PACKAGING



PRODUCT PICTURE



