



产品描述及设计理念 Product description and design philosophy

仪器的一体化结构造型，外形独特、简洁、使用寿命长，一体化结构设计具有良好的密封性能。
The instrument adopts integrated structure modeling. It has unique and simple structure and long service life. The integrated structure design has good sealing performance.

产品应用行业 Application industry

产品广泛应用于漆包线（圆线，扁线）行业、电线电缆、光缆光纤行业，铝塑复合管（塑胶管材）行业，铜带、钢带生产设备行业，五金精密加工及工具模具检测行业、微细线拉丝行业、焊丝焊带行业、钢铁冶金行业、3D打印耗材行业以及测量各种圆形及扁平物体的宽度和厚度行业。

This product is widely used in the enameled wire (round wire, flat wire) industry, wire and cable, optical fiber optic cable industry, aluminum-plastic composite pipe (plastic pipe) industry, copper strip, steel strip production equipment industry, hardware precision processing and tool mold inspection industry, micro wire drawing industry, welding wire and welding tape industry, steel metallurgy industry, 3D printing consumables industry, and the industry that measures the width and thickness of various round and flat objects.

产品工艺功能描述 Product technology and function description

- ◆ 直径值测量。
- ◆ 操作面板多角度显示。
- ◆ 全部采用优质不锈钢紧固件。
- ◆ 扫描速度600次/秒。
- ◆ 大功率激光器，长寿命光源。
- ◆ 采用铝压铸外壳，表面做喷塑处理，外观精致美观，耐腐蚀性能好。
- ◆ 采用全自动闭环控制技术及先进的DSP处理技术。
- ◆ 测量不受速度及振动影响。
- ◆ RS232/485/MODbus协议通讯接口。
- ◆ 防护等级IP65, NEMA4.
- ◆ Measurement of diameter value.
- ◆ Multi-angle display of operation panel.
- ◆ Always adopt high-quality stainless steel fasteners.
- ◆ The scanning speed is 600 times/sec.
- ◆ High-power laser, long-life light source.
- ◆ Adopt the aluminum die-casting shell, plastic spraying surface, delicate and beautiful appearance, and good corrosion resistance.
- ◆ Adopt fully automatic closed-loop control technology and advanced DSP processing technology.
- ◆ The measurement process is not affected by speed and vibration.
- ◆ RS232/485/MODbus protocol communication interface.
- ◆ Protection grade IP65, NEMA4.

产品外型及安装尺寸

Product appearance and installation size

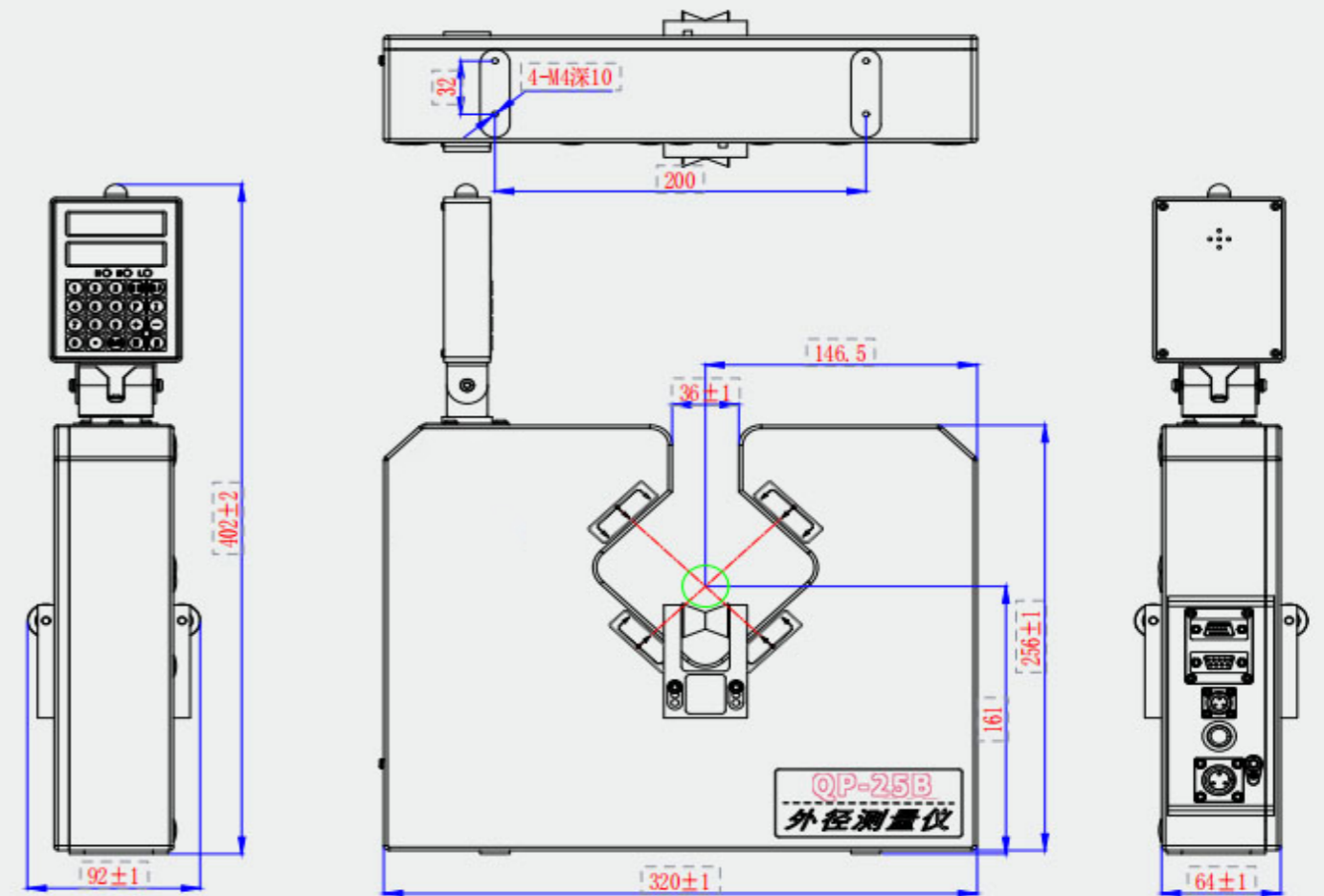

参数表

Parameter table

测量范围 Measurement scope	0.1-25mm
测量精度 Measurement accuracy	$\pm 2\mu\text{m} \pm 0.008\% \text{Dz}$ mm ("Dz"为被测物的实际直径大小) ("Dz" is the actual diameter of the measured object)
分辨率 Resolution ratio	0.001mm
扫描速度: Scanning speed	600次扫描周期/秒 600 times scanning cycle/second
供电电源 Power supply	220VAC $\pm 10\%$
工作频率 Working frequency	50/60Hz
显示方式 Display means	双排5位数码管显示 two-row 5-digit pipe display
通讯方式 Communication mode	通讯方式: 采用RS485接口与其它设备进行通讯 (通讯协议: 1.ASC II 码协议; 2.MODBUS RTU协议) Communication method: Use RS485 interface to communicate with other equipment (communication protocol: 1.ASC II code protocol; 2.MODBUS RTU protocol).
工作温度 Working temperature	0~45℃
相对湿度 Relative humidity	$\leq 85\%$ (无冷凝水) (no condensation water)
产品功耗 Power consumption	$\leq 15\text{W}$
产品尺寸 Product size	320*64*402 (L*W*H)
产品净重 Net weight	5.2Kg